

	I	GB	F	E	D		
POS.	DESCRIZIONE	DESCRIPTION	DESCRIPTION	DESCRIPCION	BESCHREIBUNG	PART. N°	QUANT.
101	BLOCCO QUADRO	CHUCK HOUSING-BARE	GUIDE AVANT-NUE	FONDO-DESNUDO	VORDERZ.-ALLEIN	8501011	1
103	SPINA PER BOCCOLA INF.	BUSH PIN	GOUJON POUR DOUILLE	VARILLA	STIFT	3501030	1
104	BOCCOLA SUPERIORE	UPPER BUSH	DOUILLE SUPERIEURE	CASQUILLO SUPER.	KOLBENHUELSE	8501040	1
105	BOCCOLA D'IMPATTO	SPACER	ENTRETOISE D'ARRET	SEPARADOR	MEISSELBUCHSE HINTEN	8501052	1
106	ANELLO DISTANZIATORE	SPACER RING	BAGUE ENTRETOISE	ANILLO SEPARADOR	RING	8501060	1
108	FERMAUTENSILE	RETAINING AXLE	AXE DE RETENUE	RETENEDOR	SPERRACHSE	8501080	2
109	NOTTOLINO	LOCK BOLT	CLIQUET D'ARRET	TORNILLO ENCLAVAM	RIEGEL	8501090	2
110	SPINA ELASTICA	ELASTIC PIN	GOUJON ELASTIQUE	PASADOR ELASTICOK	STIFT FUER BUCHSE	330131	2
111	MOLLETTA	SPRING	RESSORT	MUELLE	RIEGELFEDER	8501110	2
112	TAPPO NYLON	NYLON PLUG	BOUCHON	TAPON DE NYLON	STOPPEN	3501120	2
113	O RING	O RING	JOINT TORIQUE	JUNTA TORICA	O RING	100431	2
114	SPINA PER INGRASSAG.	GREASING PIN	GOUJON DE GRASSAGE	SPINA INGRASS.	STIFT	7001140	1
115	O RING	O RING	JOINT TORIQUE	JUNTA TORICA	O RING	100461	2
117	O RING	O RING	JOINT TORIQUE	JUNTA TORICA	O RING	100711	2
118	SPINA ELASTICA	ELASTIC PIN	GOUJON ELASTIQUE	PASADOR ELASTICOK	STIFT FUER BUCHSE	330262	2
121	SEGGIO	SEAT	SIEGE	ASIENTO	SITZ	3501210	1
122	PIATTELLO	PLATE	PLATE	PLATILLO	TELLER	3501220	1
123	GHIERA	FLANGE	COLLIER	VIROLA	ZWINGE	3501230	1
152	BOCCOLA INF. WHISPER	CHUCK BUSH WHISPER	DOUILLE INF. WHISPER	CASQUILLO INF. WHISPER	MEISSELBUCHSE WHISPER	8501520A	1
153	MANICOTTO ACCIAIO	STEEL INSERT BUSH	DOUILLE EN ACIER	MANGUITO (ACERO)	MUFFE (STAHL)	8501538	1
154	ANELLO D'ARRESTO	CIRCLIP	BAGUE	ANILLO DE BLOQUE	BLOCKIERUNG RING	8501541	1
201	CILINDRO	CYLINDER	CYLINDRE	CILINDRO	ZYLINDER	8502012	1
203	O RING	O RING	JOINT TORIQUE	JUNTA TORICA	O RING	100421	1
204	GUARNIZIONE A LABBRO	U JOINT	JOINT A LEVRES	JUNTA "U"	"U" DICHTUNG	110121	2
205	VALVOLINA	VALVE	SOUPAPE	VALVULA	VENTIL	5002050	5
206	INGRASSATORE	GREASE NIPPLE	GRAISSEUR	ENGRASADOR	SCHMIERNIPPEL	270011	1
208	PISTONE DI GUIDA	DRIVING PISTON	PISTON DE GUIDE	PISTON GUIA	FUHERUNGSKOLBEN	8502082	1
209	PISTONE MASSA ABF	PISTON ABF	PISTON ABF	PISTON ABF	SCHLAGKOLBEN ABF	8502097	1
210	RIDUZIONE DI GUIDA	GUIDE ADAPTER	DOUILLE DE CENTRAGE	ADAPTADOR GUIA	FUHERUNGSBUCHSE	8502102	1
211	SPINA DI RIFERIMENTO	PIN	GOUPILLE	PASADOR	STIFT	340141	1
301	TESTATA	HEAD	TETE	CABEZAL	KOPFTEIL	8503010A	1
302	CORPO CASSETTO	DISTRIBUTOR BOX BODY	TIROIR DE DISTRIBUT.	CAJA DE DISTRIBUCION	STEUERGEHAUSE	8503021A	1
303	O RING	O RING	JOINT TORIQUE	JUNTA TORICA	O RING	100422	1
304	DISTRIBUTORE	DISTRIBUTOR	DISTRIBUTEUR	DISTRIBUIDOR	STEUERVENTIL	8503041	1
305	COPERCHIO AMMORTIZZAT.	SHOCK ABSORBER COVER	COUVERCLE ARMOTISSEUR	TAPA AMMORTIGUADOR	DAMPFER VERTEILERSCHEIBE	8503053	1
306	DIAFRAMMA AMMORTIZZAT.	STEEL DIAPHRAGM	DIAPHRAGME ARMOTISSEUR	DIAFRAGMA AMORTIGUADOR	DAMPFER DIAPHRAGMA	1503062	1
307	TIRANTE CON GOMMA	SIDE BOLT-RUBBER	VIS TIRANT-CAOUTC.	TIRANTE CAUCHO	SEITENSCHRAUBE-PLASTIK	8503071	4
308	DADO CON INDECOIL	NUT C/W INDECOIL	ECROU AVEC INDECOIL	TORNILLO CON INDECOIL	MUTTER MIT INDECOIL	8503081 G	4

	I	GB	F	E	D		
POS.	DESCRIZIONE	DESCRIPTION	DESCRIPTION	DESCRIPCION	BESCHREIBUNG	PART. N°	QUANT.
310	SPINA DI CENTRAGGIO	CENTERING PIN	GOUPILLE	PASADOR	STIFT FUER BUCHSE	8503100A	1
313	FERMO TIRANTE	RUBBER STOP	ARRET	TOPE DE CAUCHO	KUNSTSTOFF-SICHER.	8503130	4
314	ARRESTO PER TIRANTE	SIDE BOLT LOCK	ARRET POUR TIRANT	DETENTOR TIRANTE	SEITENSCHRAUBE SPERRE	8503140	4
315	HELICOIL	HELICOIL	HELICOIL	HELICOIL	HELICOIL	280031	8
401	ATTACCO	LINK	RACCORD	CONEXION	ANSCHLUSS-GEHAUSE	5004010	2
402	RONDELLA DI TENUTA	SEALING WASHER	RONDELLE D'ETANCHEITE	ANILLO DE SELLADO	DICHTUNGSSCHEIBE	120011	2
403	TAPPO 1/4" GAS	PLUG 1/4" GAS	BOUCHON 1/4" GAS	TAPON 1/4" GAS	STOPFEN 1/4" GAS	200011	2
404	RACCORDO A.P.1-1/4"	HP CONNECTION 1-1/4"	RACCORD 1-1/4" HP	CONEXION NP 1-1/4"	1-1/4" HD ANCHLUSS	5004040	1
405	RACCORDO B.P.1-1/2"	L.P. CONNECTION 1-1/2"	RACCORD B.P. 1-1/2"	CONEXION L.P. 1-1/2"	1-1/2" ND ANSCHLUSS	5004050	1
406	O RING	O RING	JOINT TORIQUE	JUNTA TORICA	O RING	100052	4
407	RONDELLA	WASHER	RONDELLE	ARANDELA	SCHEIBE	2707192	2
408	SEEGER	SEEGER	SEEGER	RETENEDOR SEEGER	SPRENGRING	350011	2
409	VITE	SCREW	VIS	TORNILLO	SCHRAUBE	300011	8
410	O RING	O RING	JOINT TORIQUE	JUNTA TORICA	O RING	100332	2
411	CILINDRETTO	BARREL	CANON	CUERPO	BUCHSE	8504112	1
412	O RING	O RING	JOINT TORIQUE	JUNTA TORICA	O RING	100032	3
413	PISTONCINO	SLIDE	PETIT PISTON	CORREDERA	VENTILKOLBEN	8504132	1
414	MOLLA	SPRING	RESSORT	MUELLE	FEDER	400011	1
415	SPESSORE REGOLAZ.	ADJUSTMENT SHIM	RONDELLE DE CALAGE	LAMINA DE ADJUSTE	DISTANZBLECH	360011	7
416	O RING	O RING	JOINT TORIQUE	JUNTA TORICA	O RING	100071	1
418	TAPPO GUIDA	GUIDING PLUG	BOUCHON GUIDE	TAPON GUIA	FUEHRUNGSTOPFEN	8504180A	1
419	DISCO DISTANZIATORE	SPACING DISK	DISQUE ENTRETOISE	DISCO SEPARADOR	SEPARATOR PLATTE	3504190	1
420	SPESSORE REGOLAZ.	ADJUSTMENT SHIM	RONDELLE DE CALAGE	LAMINA DE ADJUSTE	DISTANZBLECH	360071	2
431	CORPO SPILLO	VALVE BODY	CORPS SOUPAPE	CUERPO VALVULA	NADELVENTIL	3504315	1
432	SPILLO	NEEDLE	POINTEAU	VALVULA	NADEL	3504325	1
434	MOLLA	SPRING	RESSORT	MUELLE	FEDER	400061	1
435	CILINDRETTO DISTANZ.	SPACER BARREL	ENTRETOISE	SEPARADOR	BUCHSE	340111	1
436	O RING	O RING	JOINT TORIQUE	JUNTA TORICA	O RING	100171	1
437	SPESSORE REGOLAZ.	ADJUSTMENT SHIM	RONDELLE DE CALAGE	LAMINA DE ADJUSTE	DISTANZBLECH	360021	7
438	TAPPO PER VARIABILE	PLUG	BOUCHON	TAPON	STOPFEN	3504380	1
501	MEZZA CAPSULA INF.	HALF LOWER SHELL	FLASQUE INFERIEUR	ALOJAMIENTO INFER.	AKKUM. KAPSEL-UNTEN	8505010	1
502	MEZZA CAPSULA SUP.	HALF UPPER SHELL	FLASQUE SUPERIEUR	ALOJAMIENTO SUP.	AKKUM. KAPSEL-OBEN	8505020	1
503	MEMBRANA (POLIURET.)	DIAPH. (POLYURETHANE)	MEMBRANE (POLY)	DIAFRAGMA (POLY)	MEMBRANE (POLY)	8505030 P	1
504	VITE CARICA AZOTO	INFLATING SCREW	VIS DE GONFLAGE	TORNILLO DE INFLADO	FUELLSC. STICKSTOFF	2704041	1
505	ANELLO DI TENUTA	SEALING RING	BAGUE D'ETANCHEITE	ANILLO DE SELLADO	DICHTUNG	120021	1
506	VITE CHIUSURA CAPS.	SHELL FIXING SCREW	VIS DE FERMETURE	TORNILLO	SCHRAUBE	300191	16
507	VITE D'ANCORAGGIO	FIXING SCREW	VIS D'ANCRAGE	TORNILLO FIXACION	VERSCHLUSSSCHRAUBE	8505070	8
508	O RING	O RING	JOINT TORIQUE	JUNTA TORICA	O RING	100602	1



	I	GB	F	E	D		
POS.	DESCRIZIONE	DESCRIPTION	DESCRIPTION	DESCRIPCION	BESCHREIBUNG	PART. N°	QUANT.
101	BLOCCO QUADRO	CHUCK HOUSING-BARE	GUIDE AVANT-NUE	FONDO-DESNUDO	VORDERZ.-ALLEIN	8501011	1
103	SPINA PER BOCCOLA INF.	BUSH PIN	GOUJON POUR DOUILLE	VARILLA	STIFT	3501030	1
104	BOCCOLA SUPERIORE	UPPER BUSH	DOUILLE SUPERIEURE	CASQUILLO SUPER.	KOLBENHUELSE	8501040	1
105	BOCCOLA D'IMPATTO	SPACER	ENTRETOISE D'ARRET	SEPARADOR	MEISSELBUCHSE HINTEN	8501052	1
106	ANELLO DISTANZIATORE	SPACER RING	BAGUE ENTRETOISE	ANILLO SEPARADOR	RING	8501060	1
108	FERMAUTENSILE	RETAINING AXLE	AXE DE RETENUE	RETENEDOR	SPERRACHSE	8501080	2
109	NOTTOLINO	LOCK BOLT	CLIQUET D'ARRET	TORNILLO ENCLAVAM	RIEGEL	8501090	2
110	SPINA ELASTICA	ELASTIC PIN	GOUJON ELASTIQUE	PASADOR ELASTICOK	STIFT FUER BUCHSE	330131	2
111	MOLLETTA	SPRING	RESSORT	MUELLE	RIEGELFEDER	8501110	2
112	TAPPO NYLON	NYLON PLUG	BOUCHON	TAPON DE NYLON	STOPPEN	3501120	2
113	O RING	O RING	JOINT TORIQUE	JUNTA TORICA	O RING	100431	2
114	SPINA PER INGRASSAG.	GREASING PIN	GOUJON DE GRASSAGE	SPINA INGRASS.	STIFT	7001140	1
115	O RING	O RING	JOINT TORIQUE	JUNTA TORICA	O RING	100461	2
117	O RING	O RING	JOINT TORIQUE	JUNTA TORICA	O RING	100711	2
118	SPINA ELASTICA	ELASTIC PIN	GOUJON ELASTIQUE	PASADOR ELASTICOK	STIFT FUER BUCHSE	330262	2
121	SEGGIO	SEAT	SIEGE	ASIENTO	SITZ	3501210	1
122	PIATTELLO	PLATE	PLATE	PLATILLO	TELLER	3501220	1
123	GHIERA	FLANGE	COLLIER	VIROLA	ZWINGE	3501230	1
152	BOCCOLA INF. WHISPER	CHUCK BUSH WHISPER	DOUILLE INF. WHISPER	CASQUILLO INF. WHISPER	MEISSELBUCHSE WHISPER	8501520A	1
153	MANICOTTO PLASTICA	COMPOSITE BUSH	DOUILLE SYNTETIQUE	MANGUITO	MUFFE	8501530	1
154	ANELLO D'ARRESTO	CIRCLIP	BAGUE	ANILLO DE BLOQUE	BLOCKIERUNG RING	8501541	1
201	CILINDRO	CYLINDER	CYLINDRE	CILINDRO	ZYLINDER	8502012	1
203	O RING	O RING	JOINT TORIQUE	JUNTA TORICA	O RING	100421	1
204	GUARNIZIONE A LABBRO	U JOINT	JOINT A LEVRES	JUNTA "U"	"U" DICHTUNG	110121	2
205	VALVOLINA	VALVE	SOUPAPE	VALVULA	VENTIL	5002050	5
206	INGRASSATORE	GREASE NIPPLE	GRAISSEUR	ENGRASADOR	SCHMIERNIPPEL	270011	1
208	PISTONE DI GUIDA	DRIVING PISTON	PISTON DE GUIDE	PISTON GUIA	FUHERUNGSKOLBEN	8502082	1
209	PISTONE MASSA ABF	PISTON ABF	PISTON ABF	PISTON ABF	SCHLAGKOLBEN ABF	8502097	1
210	RIDUZIONE DI GUIDA	GUIDE ADAPTER	DOUILLE DE CENTRAGE	ADAPTADOR GUIA	FUHERUNGSBUCHSE	8502102	1
211	SPINA DI RIFERIMENTO	PIN	GOUPILLE	PASADOR	STIFT	340141	1
301	TESTATA	HEAD	TETE	CABEZAL	KOPFTEIL	8503010A	1
302	CORPO CASSETTO	DISTRIBUTOR BOX BODY	TIROIR DE DISTRIBUT.	CAJA DE DISTRIBUCION	STEUERGEHAUSE	8503021A	1
303	O RING	O RING	JOINT TORIQUE	JUNTA TORICA	O RING	100422	1
304	DISTRIBUTORE	DISTRIBUTOR	DISTRIBUTEUR	DISTRIBUIDOR	STEUERVENTIL	8503041	1
305	COPERCHIO AMMORTIZZAT.	SHOCK ABSORBER COVER	COUVERCLE ARMOTISSEUR	TAPA AMMORTIGUADOR	DAMPFER VERTEILERSCHEIBE	8503053	1
306	DIAFRAMMA AMMORTIZZAT.	STEEL DIAPHRAGM	DIAPHRAGME ARMOTISSEUR	DIAFRAGMA AMORTIGUADOR	DAMPFER DIAPHRAGMA	1503062	1
307	TIRANTE CON GOMMA	SIDE BOLT-RUBBER	VIS TIRANT-CAOUTC.	TIRANTE CAUCHO	SEITENSCHRAUBE-PLASTIK	8503071	4
308	DADO CON INDECOIL	NUT C/W INDECOIL	ECROU AVEC INDECOIL	TORNILLO CON INDECOIL	MUTTER MIT INDECOIL	8503081 G	4

	I	GB	F	E	D		
POS.	DESCRIZIONE	DESCRIPTION	DESCRIPTION	DESCRIPCION	BESCHREIBUNG	PART. N°	QUANT.
310	SPINA DI CENTRAGGIO	CENTERING PIN	GOUPILLE	PASADOR	STIFT FUER BUCHSE	8503100A	1
313	FERMO TIRANTE	RUBBER STOP	ARRET	TOPE DE CAUCHO	KUNSTSTOFF-SICHER.	8503130	4
314	ARRESTO PER TIRANTE	SIDE BOLT LOCK	ARRET POUR TIRANT	DETENTOR TIRANTE	SEITENSCHRAUBE SPERRE	8503140	4
315	HELICOIL	HELICOIL	HELICOIL	HELICOIL	HELICOIL	280031	8
401	ATTACCO	LINK	RACCORD	CONEXION	ANSCHLUSS-GEHAUSE	5004010	2
402	RONDELLA DI TENUTA	SEALING WASHER	RONDELLE D'ETANCHEITE	ANILLO DE SELLADO	DICHTUNGSSCHEIBE	120011	2
403	TAPPO 1/4" GAS	PLUG 1/4" GAS	BOUCHON 1/4" GAS	TAPON 1/4" GAS	STOPFEN 1/4" GAS	200011	2
404	RACCORDO A.P.1-1/4"	HP CONNECTION 1-1/4"	RACCORD 1-1/4" HP	CONEXION NP 1-1/4"	1-1/4" HD ANCHLUSS	5004040	1
405	RACCORDO B.P.1-1/2"	L.P. CONNECTION 1-1/2"	RACCORD B.P. 1-1/2"	CONEXION L.P. 1-1/2"	1-1/2" ND ANSCHLUSS	5004050	1
406	O RING	O RING	JOINT TORIQUE	JUNTA TORICA	O RING	100052	4
407	RONDELLA	WASHER	RONDELLE	ARANDELA	SCHEIBE	2707192	2
408	SEEGER	SEEGER	SEEGER	RETENEDOR SEEGER	SPRENGRING	350011	2
409	VITE	SCREW	VIS	TORNILLO	SCHRAUBE	300011	8
410	O RING	O RING	JOINT TORIQUE	JUNTA TORICA	O RING	100332	2
411	CILINDRETTO	BARREL	CANON	CUERPO	BUCHSE	8504112	1
412	O RING	O RING	JOINT TORIQUE	JUNTA TORICA	O RING	100032	3
413	PISTONCINO	SLIDE	PETIT PISTON	CORREDERA	VENTILKOLBEN	8504132	1
414	MOLLA	SPRING	RESSORT	MUELLE	FEDER	400011	1
415	SPESSORE REGOLAZ.	ADJUSTMENT SHIM	RONDELLE DE CALAGE	LAMINA DE ADJUSTE	DISTANZBLECH	360011	7
416	O RING	O RING	JOINT TORIQUE	JUNTA TORICA	O RING	100071	1
418	TAPPO GUIDA	GUIDING PLUG	BOUCHON GUIDE	TAPON GUIA	FUEHRUNGSTOPFEN	8504180A	1
419	DISCO DISTANZIATORE	SPACING DISK	DISQUE ENTRETOISE	DISCO SEPARADOR	SEPARATOR PLATTE	3504190	1
420	SPESSORE REGOLAZ.	ADJUSTMENT SHIM	RONDELLE DE CALAGE	LAMINA DE ADJUSTE	DISTANZBLECH	360071	2
431	CORPO SPILLO	VALVE BODY	CORPS SOUPAPE	CUERPO VALVULA	NADELVENTIL	3504315	1
432	SPILLO	NEEDLE	POINTEAU	VALVULA	NADEL	3504325	1
434	MOLLA	SPRING	RESSORT	MUELLE	FEDER	400061	1
435	CILINDRETTO DISTANZ.	SPACER BARREL	ENTRETOISE	SEPARADOR	BUCHSE	340111	1
436	O RING	O RING	JOINT TORIQUE	JUNTA TORICA	O RING	100171	1
437	SPESSORE REGOLAZ.	ADJUSTMENT SHIM	RONDELLE DE CALAGE	LAMINA DE ADJUSTE	DISTANZBLECH	360021	7
438	TAPPO PER VARIABILE	PLUG	BOUCHON	TAPON	STOPFEN	3504380	1
501	MEZZA CAPSULA INF.	HALF LOWER SHELL	FLASQUE INFERIEUR	ALOJAMIENTO INFER.	AKKUM. KAPSEL-UNTEN	8505010	1
502	MEZZA CAPSULA SUP.	HALF UPPER SHELL	FLASQUE SUPERIEUR	ALOJAMIENTO SUP.	AKKUM. KAPSEL-OBEN	8505020	1
503	MEMBRANA (POLIURET.)	DIAPH. (POLYURETHANE)	MEMBRANE (POLY)	DIAFRAGMA (POLY)	MEMBRANE (POLY)	8505030 P	1
504	VITE CARICA AZOTO	INFLATING SCREW	VIS DE GONFLAGE	TORNILLO DE INFLADO	FUELLSC. STICKSTOFF	2704041	1
505	ANELLO DI TENUTA	SEALING RING	BAGUE D'ETANCHEITE	ANILLO DE SELLADO	DICHTUNG	120021	1
506	VITE CHIUSURA CAPS.	SHELL FIXING SCREW	VIS DE FERMETURE	TORNILLO	SCHRAUBE	300191	16
507	VITE D'ANCORAGGIO	FIXING SCREW	VIS D'ANCRAGE	TORNILLO FIXACION	VERSCHLUSSSCHRAUBE	8505070	8
508	O RING	O RING	JOINT TORIQUE	JUNTA TORICA	O RING	100602	1



# HP 9000 - HP 9000 W



ESPLOSO • EXPLODED VIEW • NUE ECLATEE • EXPLOSO • ERSATZTEIL-ZEICHNEN

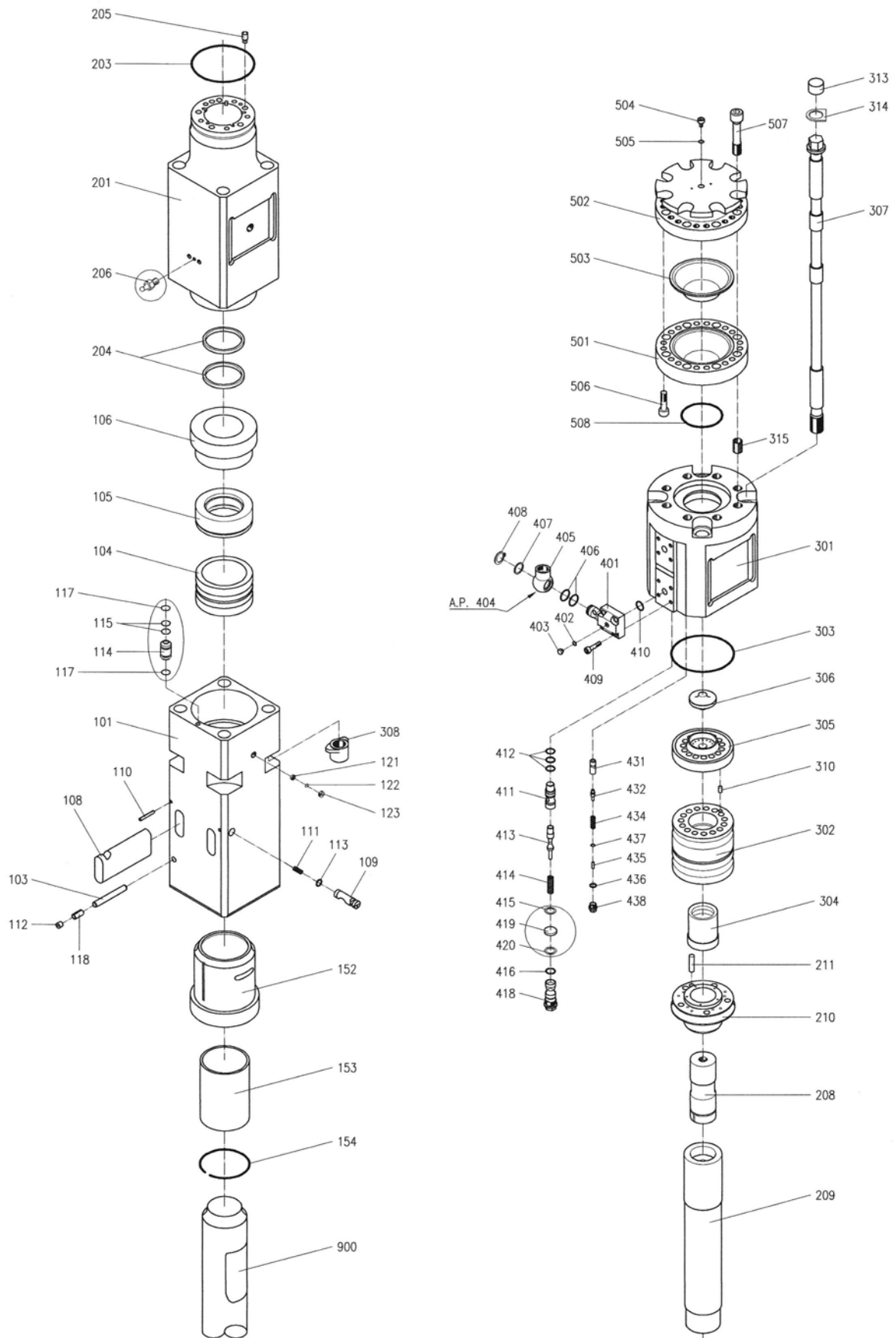

# HP 9000 - HP 9000 W



ESPLOSO • EXPLODED VIEW • NUE ECLATEE • EXPLOSO • ERSATZTEIL-ZEICHNEN

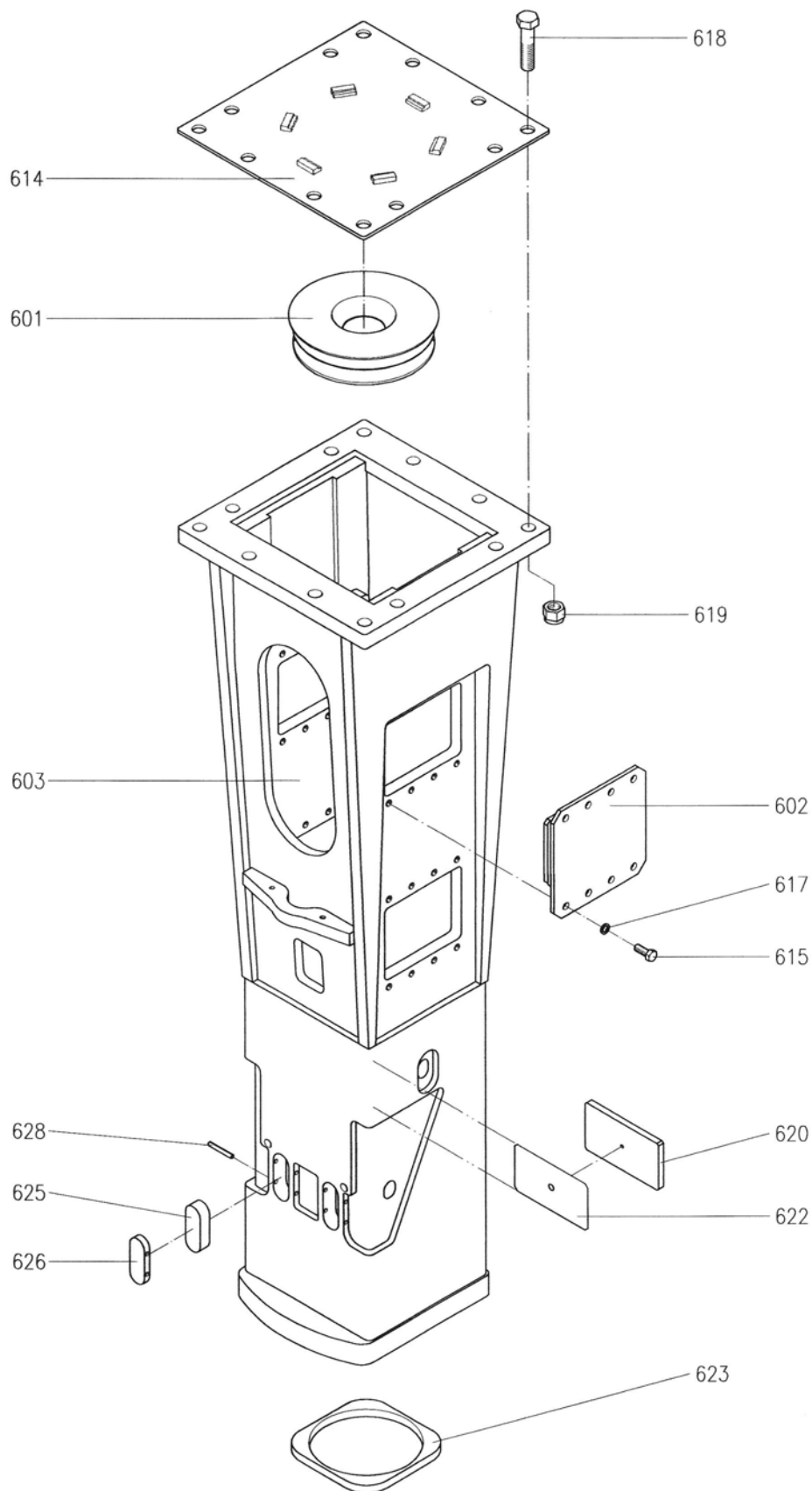



# HP 9000 - HP 9000 W



SPECIFICA TECNICA • TECHNICAL SPECIFICATION • SPECIFICATION TECHNIQUE • NOTA TECNICA • TECHNISCHE SPEZIFIKATION

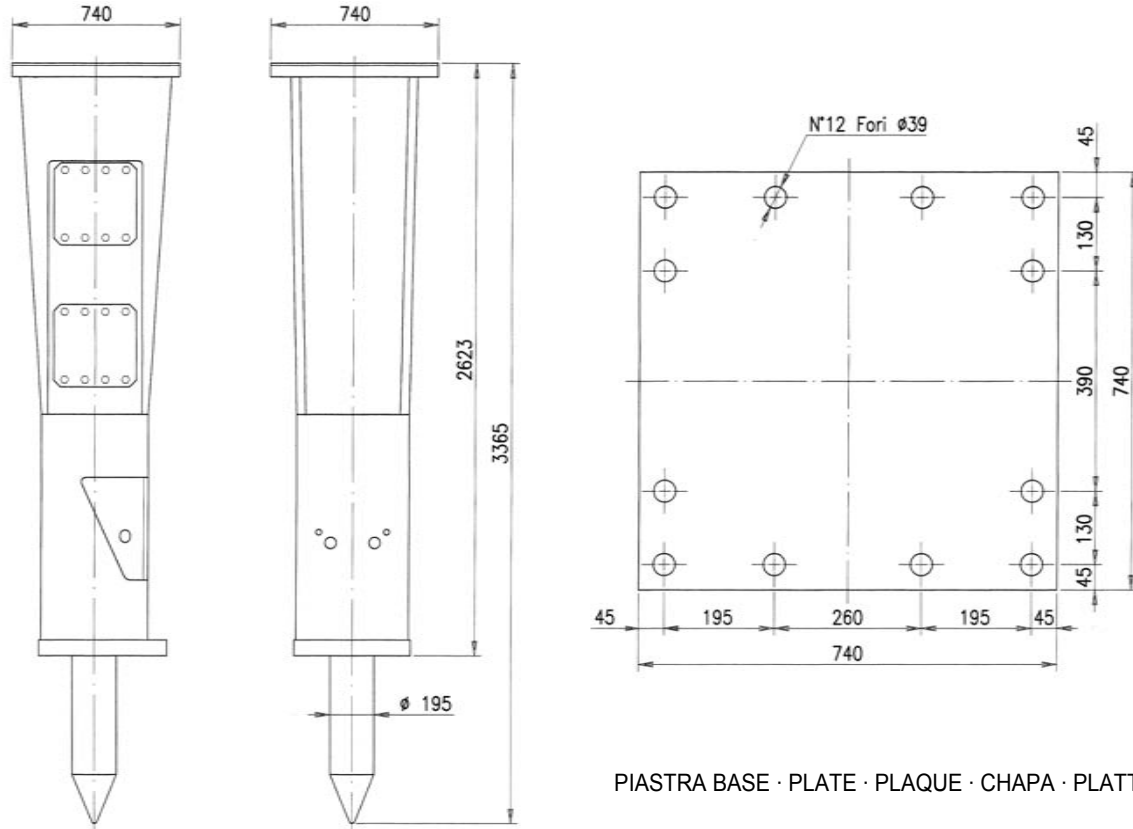

PIASTRA BASE · PLATE · PLAQUE · CHAPA · PLATTE: min. 50mm

I	GB	F	E	D	
PESO ESCAVATORE	SUITABLE ESCAVATOR	POIDS PELLE	PESO EXCAVADORA	GEEIGNET FÜR TRÄGERGERÄT	39 ÷ 80 ton
PESO OPERATIVO (CON SELLA E UTENSILE)	OPERATING WEIGHT (WITH MOUNTING BRACKET AND TOOL)	POIDS OPERATION (AVEC PLATINE ET OUTIL)	PESO OPERATIVO (CON CABEZAL E UTIL)	ARBEITSGEWICHT (MIT ADAPTERPLATTE UND MEISSEL)	5000 kg
PESO (SENZA SELLA E UTENSILE)	OPERATING WEIGHT (WITHOUT MOUNTING BRACKET AND TOOL)	POIDS OPERATION (SANS PLATINE ET OUTIL)	PESO OPERATIVO (SIN CABEZAL E UTIL)	ARBEITSGEWICHT (OHNE ADAPTERPLATTE UND MEISSEL)	4300 kg
DIAMETRO UTENSILE	STEEL DIAMETER	DIAMETRE OUTIL	DIAMETRO DE LA HERRAMIENTA	MEISSELDURCHMESSER	195 mm
ATTACCHI AL MARTELLO ENTRATA	HOSE CONNECTION AT THE BREAKERS INLET LINE	JOINTAGE AU BRISEROCHE ENTREE	DIAMETRO DE LA CONEXION ENTRADA AL MARTILLO	HAMMER-ANSCHLUSSSCHLAUCH VORLAUF	1 1/4" Gas
ATTACCHI AL MARTELLO USCITA	HOSE CONNECTION AT THE BREAKERS RETURN LINE	JOINTAGE AU BRISEROCHE SORTIE	DIAMETRO DE LA CONEXION SAIDA AL MARTILLO	HAMMER-ANSCHLUSSSCHLAUCH BÜCKLAUF	1 1/2" Gas
TUBAZIONE IMPIANTO (raccom.) TUBO MANDATA (min. in dia)	INLET LINE SIZE RECOMMENDATION (min.)	DIAMETRE TUYAN H.P. (min.)	DIAMETRO TUBO DE ENTRADA (min.)	VORLAUF-LEITUNGSGRÖSSE EMPFOHLEN (min.)	35 mm
TUBAZIONE IMPIANTO (raccom.) TUBO RITORNO (min. in dia)	RETURN LINE SIZE RECOMMENDATION (min.)	DIAMETRE TUYAN B.P. (min.)	DIAMETRO TUBO DE DESCARGA (min.)	RÜCKLAUF-LEITUNGSGRÖSSE EMPFOHLEN (min.)	42 mm
PORTATA DA EROGARE	OIL SUPPLY	DEBIT AU BRISEROCHE	CAUDAL DA SUMINISTRAR	ÖLBEDARF	290 ÷ 355 l/min
PRESSIONE REGOLATA AL MARTELLO	BREAKER WORKING PRESSURE	PRESSION REGLEE AU BRISE ROCHE	PRESION REGULADA AL MARTILLO	ARBEITSÖLDRUCK IM HYDRAULIKHAMMER	140 ÷ 165 bar
PRESSIONE REGOLATA ALL'ESCAVATORE	RELIEF PRESSURE SETTING	PRESSION REGLEE A LA PELLE	PRESION REGULADA A LA EXCAVADORA	ARBEITSÖLDRUCK VOM TRÄGERGERÄT	210 bar
CONTROPRESSIONE SUL MARTELLO (MAX)	BACK-PRESSURE AT THE BREAKER (MAX)	CONTRE PRESSION AU BRISE ROCHE (MAX)	CONTRAPRESION AL MARTILLO (MAX)	RÜCKLAUF-STAUDRUCK AM HYDRAULIKHAMMER (MAX)	8 bar
ENERGIA D'URTO (MAX)	IMPACT ENERGY (MAX)	PUISSANCE DE CHOC (MAX)	ENERGIA DE CHOQUE (MAX)	EINZELSCHLAG-ENERGIE (MAX)	14120 Joule
NUMERO COLPI AL MINUTO	IMPACT RATE	FRAPPES PAR MINUTE	GOLPES AL MINUTO	SCHLAGZAHL PRO MINUTE	270 ÷ 540 n/min
POTENZA INGRESSO (MAX)	INPUT POWER (MAX)	PUISSANCE ENTREE (MAX)	POTENCIA ENTRADA (MAX)	EINGANGS-GEWALT (MAX)	82 kw
VISCOSITÀ OLIO IDRAULICO	HYDRAULIC OIL VISCOSITY	VISCOSITE DE L'HUILE HIDR.	VISCOSODAD DELACEITE HIDR.	VISKOSITÄT DES HYDRAULIKÖLES	15 ÷ 90 Cst
LUNGHEZZA SUGGERITA TUBI FLESSIBILI	SUGGESTED MIN FLEX HOSES LENGHT	LONGUEUR DES FLEXIBLES	LARG. TUBOS FLEXIBLES	HAMMER-ANSCHLUSSSCHLAUCH LANGE	3000 mm

# HP 9000 - HP 9000 W



COPPIE DI SERRAGGIO VITI E PRESSIONE CARICA AZOTO • TORQUE SETTING SCREWS AND NITROGEN CHARGING PRESSURE • COUPLE SERRAGE DES VIS ET PRESSION GONFLAGE AZOTE • PAR DE TORSION TORNILLOS Y PRESION CARGA DE NITROGENO • ANZUG DREHI MOMENT LADEN DRUCK STICKSTOFF

I	GB	F	E	D			
PARTICOLARE	PART	COMPOSANTE	PARTES	BESTANDTEIL	POS.	KEY	MKG
TIRANTE	SIDE BOLTS	TIRANT	TIRANTE	SETTENSCHRAUBE	307	55	140*
VITE VALVOLA PRESSIONE	GUIDING PLUG	BOUCHON GUIDE	TAPON GUIA	STOPFEN	418	41	100
VITE VALVOLA VARIABILE	GUIDING PLUG	BOUCHON GUIDE	TAPON GUIA	STOPFEN	438	24	25
VITE TAPPO TEST PRES.	1/4" PLUG	1/4" BOUCHON	1/4" TAPON	1/4" STOPFEN	403	19	4
VITE AMMORTIZZATORI LATERALI	SHOCK ABSORBER-SIDE SCREW	VIS AMORTISSEUR LATERAL	TORNILLO AMORTIGUADOR LATERAL	SCHRAUBE DAEMPFER-SEITLICH	615	30	32
VITE SERRAGGIO ATTACCO	SCREW	VIS D'ANCRAGE	TORNILLO	SCHRAUBE	409	B 14	18
VITE CARICAAZOTO	INFLATING SCREW	VIS DE GONFLAGE	TORNILLO PARA INFLAR	FUELLSCHRAUBE STICKSTOFF	504	B 14	5
VITE ANCORAGGIO CAPSULA	FIXING SCREW	VIS D'ANCRAGE	TORNILLO FIJACION	VERSCHLUS-SCHRAUBE	507	B 27	150
VITE CHIUSURA CAPSULA	SELL FIXING SCREW	VIS DE FERMETURE	TORNILLO	SCHRAUBE	506	B 19	70
GHIERA	FLANGE	COLLIER	VIROLA	ZWINGE	123	B 12	25
VITE ATTACCO SELLA	CRADLE SCREW	VIS POUR CHAPEAU	TORNILLO	SCHRAUBE FUER SATTEL	618	55	190
PRESS. CARICA AZOTO OLIO 60°C	NITROGEN CHARGING PRESS. (AT OIL TEMP. 60°C)	PRESS. GONFLAGE AZOTE (TEMP. HUILE 60° C)	PRESION CARGA DE NITROGENO (ACEITE TEMP. 60° C)	LADEN DRUCK STICKSTOFF (OL TEMP. 60° C)	40 bars		
PRESS. CARICA AZOTO OLIO 70°C	NITROGEN CHARGING PRESS. (AT OIL TEMP. 70°C)	PRESS. GONFLAGE AZOTE (TEMP. HUILE 70° C)	PRESION CARGA DE NITROGENO (ACEITE TEMP. 70° C)	LADEN DRUCK STICKSTOFF (OL TEMP. 70° C)	35 bars		

\*Applicare il valore di precarico indicato serrando a croce ed a rotazione in più fasi di avviamento. Quindi, seguendo sempre la stessa tecnica, avvitare di 180° + 15°~ . A fase ultimata svitare ciascun tirante di 15°~.

\*Apply the indicated pre-load, cross tightening and rotating the bolts in several phases. Then using the same technique, turn 180° + 15°~. When the phase has been completed unscrew each side bolt by 15°~.

\*Appliquer la valeur de précharge indiquée, en serrant à l'aide d'un tournevis en croix en plusieurs tours., Puis, en utilisant toujours la même technique, visser de 180° + 15°~. Une fois cette phase terminée, dévisser chacun des tirants de 15°~.

\*Adaptar el valor de carga previa indicado, apretando en forma de cruz y atornillando en varias fases con un movimiento de rotación. A continuación, con la misma técnica, atornillar 180° + 15°~. Una vez concluida esta fase, aflojar todos los tirantes 15°~.

\*Legen Sie die angegebenen Werte der Vorspannung an, in dem Sie überkreuz und in Drehrichtung in mehreren Verschraubungsphasen anschrauben; dann, immer mit derselben Technik, um 180° + 15°~ anschrauben. Zum schluß lösen Sie Jeden Zuganker um 15°~.

