

C12VE

Clamshell Bucket with Exchangeable Shells

Clamshell Bucket with exchangeable shells and vertical cylinders for excavators from 9t / 19800 lbs to 12t / 26400 lbs operating weight – through quick and easy exchange of shells, the C12VE is ideal for different applications, for excavation operations, landscaping, trench digging, handling of logs and more. The shells can be changed in less than four minutes.

- Economic solution as only the shells have to be exchanged to switch applications – bucket carrier, hydraulics and bearings are integrated into the main carrier.
- Long life is ensured due to the use of 500 HB steel in the manufacture of cutting edges.
- Reduced wear resulting from generously dimensioned bearing system.
- Excellent digging characteristics are the result of high closing forces (39 kN / 8580 lbf at an operating pressure of 32 MPa / 4608 psi).

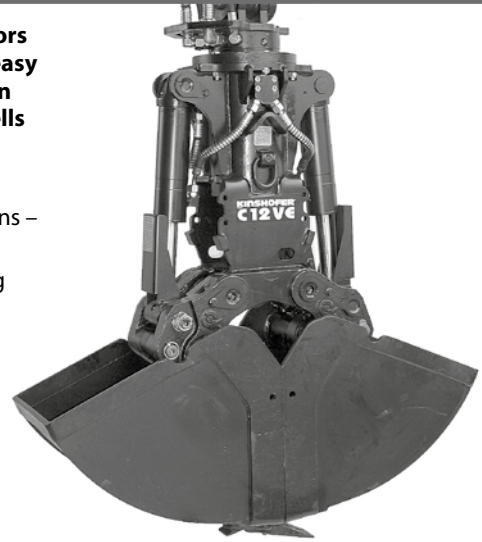

Clamshell Bucket C12VE								
Type	Width E (mm/in)	Opening A* (mm/in)	Height C max.* (mm/in)	Length F (mm/in)	Volume (litre/c.y.)	Number of teeth	Self weight (kg/lbs)	Load capacity (kg/lbs)
C12VE-32	325 / 12.80	1645 / 64.76	1570 / 61.81	1350 / 53.15	125 / 0.16	3	475 / 1045	4500 / 9900
C12VE-40	400 / 15.75	1645 / 64.76	1570 / 61.81	1350 / 53.15	160 / 0.21	3	485 / 1067	4500 / 9900
C12VE-50	500 / 19.69	1645 / 64.76	1570 / 61.81	1350 / 53.15	200 / 0.26	5	500 / 1100	4500 / 9900
C12VE-60	600 / 23.62	1645 / 64.76	1570 / 61.81	1350 / 53.15	245 / 0.32	5	515 / 1133	4500 / 9900
C12VE-70	700 / 27.56	1645 / 64.76	1570 / 61.81	1350 / 53.15	285 / 0.37	7	525 / 1155	4500 / 9900
C12VE-80	800 / 31.50	1645 / 64.76	1570 / 61.81	1350 / 53.15	330 / 0.43	9	535 / 1177	4500 / 9900

Package consists of: clamshell bucket, bolt-on teeth, **KINSHOFER** rotator, non-return valve and hose guard, 2 welded eyes * incl. teeth

KINSHOFER Rotator

Continuous rotation and two oil passages. Overload protection is ensured by pressure relief valves.

Type	Upper connection (width x pin-Ø) (mm/in)	Torque (Nm/ft.lbs)	Moment of deflection max. (Nm/ft.lbs)
KM 10 F275-50	110 x 50 / 4.33 x 1.97	2000 / 1475	14000 / 10325

Accessories

Type	Description
KM 501 9t-12t	upper suspension without pendulum damper
KM 511 9t-12t	upper suspension with pendulum damper
SW08 cardanic	adapter for Lehnhoff grab exchange system SW/MS08 without suspension – up to 12t / 26400 lbs
SW10 cardanic	adapter for Lehnhoff grab exchange system SW/MS10 without suspension – up to 19t / 41800 lbs
	adapter for quick exchange systems from other manufacturers available
KM 680 C12VE/C18VE	scraper

Requirements of Excavator

Operating pressure (open/close):	max. 32 MPa (320 bar) / 4608 psi
Pump capacity (open/close):	40 - 120 l/min / 10.57 - 31.70 GPM
Operating pressure (rotation):	max. 32 MPa (320 bar) / 4608 psi
Pump capacity (rotation):	20 - 50 l/min / 5.28 - 13.21 GPM

Technical Drawings

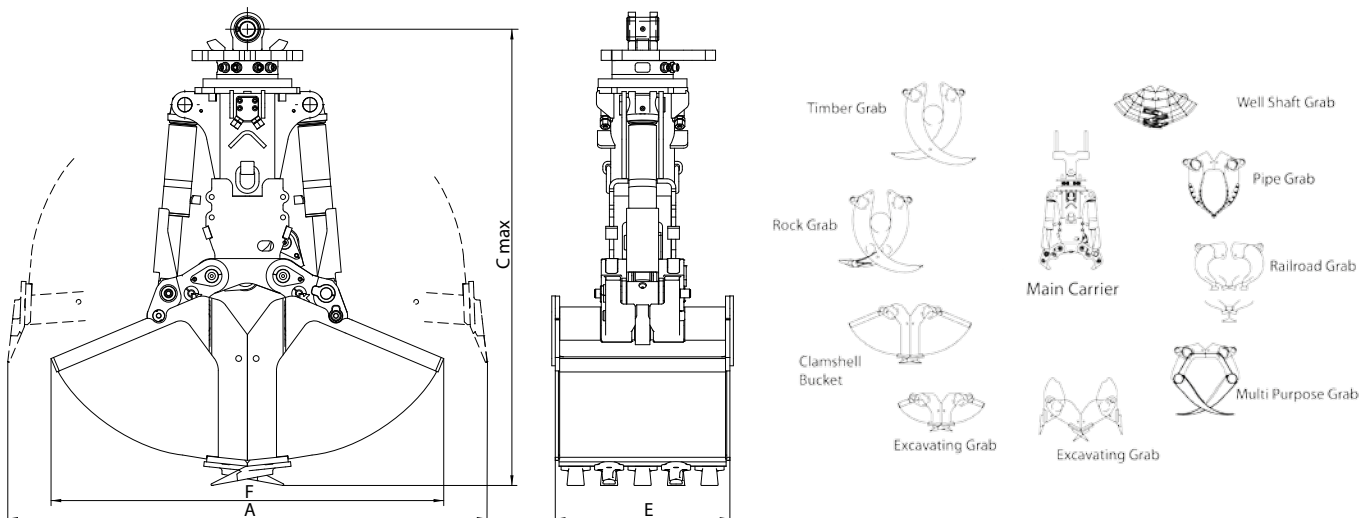

Exchangeable Shells

C12VE

Exchangeable Shells for C12VE

Shells are interchangeable and available in all widths. Rapid exchange with shell stand and pin exchange tool

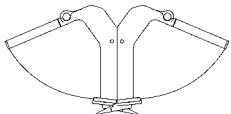
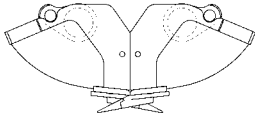
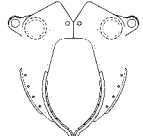
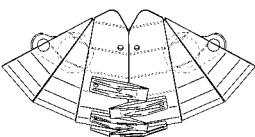
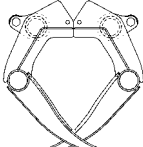
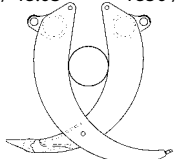
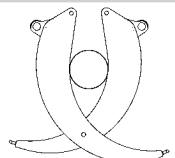
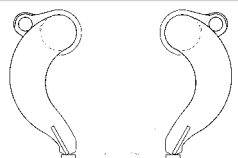
Type	Width (mm/in)	Opening (mm/in)	Height overall (mm/in)	Volume (litre/c.y.)	Number of teeth	Weight of shells (kg/lbs)	Self weight (kg/lbs)	Load capacity (kg/lbs)	Closing force (kN/lbf)
Clamshell Bucket									
C12VE-32S	325 / 12.80	1535 / 60.43	1570 / 61.81	125 / 0.16	3	130 / 286	480 / 1056	4500 / 9900	39 / 8580
C12VE-40S	400 / 15.75	1535 / 60.43	1570 / 61.81	160 / 0.21	3	140 / 308	495 / 1089	4500 / 9900	39 / 8580
C12VE-50S	500 / 19.69	1535 / 60.43	1570 / 61.81	200 / 0.26	5	165 / 363	515 / 1133	4500 / 9900	39 / 8580
C12VE-60S	600 / 23.62	1535 / 60.43	1570 / 61.81	245 / 0.32	5	180 / 396	530 / 1166	4500 / 9900	39 / 8580
C12VE-70S	700 / 27.56	1535 / 60.43	1570 / 61.81	285 / 0.37	7	205 / 451	555 / 1221	4500 / 9900	39 / 8580
C12VE-80S	800 / 31.50	1535 / 60.43	1570 / 61.81	330 / 0.43	9	225 / 495	575 / 1265	4500 / 9900	39 / 8580
Excavating Grab									
C12VE-32S EG	325 / 12.80	1200 / 47.24	1350 / 53.15	90 / 0.12	3	110 / 242	450 / 990	4500 / 9900	52 / 11440
C12VE-40S EG	400 / 15.75	1100 / 43.31	1355 / 53.35	55 / 0.07	3	125 / 275	475 / 1045	4500 / 9900	55 / 12100
C12VE-80S EG	800 / 31.50	800 / 31.50	1350 / 53.15	100 / 0.13	9	155 / 341	505 / 1111	4500 / 9900	63 / 13860
Pipe Grab									
C12VE-80S PG	800 / 31.50	Ø75-560 / 2.95-22.05	1590 / 62.60	-	-	145 / 319	485 / 1067	4500 / 9900	39 / 8580
Well Shaft Grab									
C12VE-100S WSG	Ø1000 / 39.37	1000 / 39.37	1320 / 51.97	100 / 0.13	5	140 / 308	480 / 1056	4500 / 9900	60 / 13200
Please note: larger shells are available on request									
Multi Purpose Grab									
A12VE-94S	940 / 37.01	1850 / 72.83	1695 / 66.73	400 / 0.52	-	205 / 451	550 / 1210	4500 / 9900	39 / 8580
A12VE-122S	1220 / 48.03	1850 / 72.83	1695 / 66.73	600 / 0.78	-	240 / 528	595 / 1309	4500 / 9900	39 / 8580
Rock Grab									
R12VE-48S	480 / 18.90	1850 / 72.83	1790 / 70.47	0,50 m ² / 0.33 cords	-	200 / 440	555 / 1221	4500 / 9900	30 / 6600
Timber Grab									
T12VE-47S	470 / 18.50	1835 / 72.24	1795 / 70.67	0,50 m ² / 0.33 cords	-	180 / 396	535 / 1177	4500 / 9900	30 / 6600
Railroad Grab									
C12VE-50S RG	500 / 19.69	1350 / 53.15	1405 / 55.31	-	-	135 / 297	485 / 1067	4500 / 9900	44 / 9680

Package consists of: exchangeable buckets, shell stand and pin exchange tool

Please note: special buckets are available on request